



## Features and Specifications

- 94-092A1
- Above ground or pit
- 2,500 - 20,000 lbs. - NTEP Approved Capacities
- 80% for 2.5K capacity  
100% for 5K to 20K capacities
- 4-3/8" nominal (2.5K - 10K SE) adjustable  
5-3/8" nominal (10K LE - 20K) adjustable
- 2' x 2' - 8' x 10' - NTEP Approved Sizes  
Any custom size platform available - 18" x 18" to 10' x 12'
- Laser cut 1/4" carbon steel tread plate with formed channel sub-structure (2.5K - 10K)  
Laser cut 3/8" carbon steel tread plate with structural channel sub-structure (20k)
- Top access junction box, leveling foot adjustment holes, threaded lifting eye bolt holes
- Cross-Linked two-part Epoxy - 2 to 4 mil primer base coat  
Two-part UV resistant Polyurethane - 2 to 4 mil top coat
- Plated alloy steel, 350 Ohms, 3.0mV/V
  - 2.5K capacity: (4) 1,000 lb. cells
  - 5K capacity: (4) 4,000 lb. cells
  - 10K SE capacity: (4) 5,000 lb. cells (small envelope)
  - 10K LE capacity: (4) 5,000 lb. cells (large envelope)
  - 20K capacity: (4) 10,000 lb. cell
- B-TEK stainless steel ball encapsulated foot
- NEMA 4 fiberglass reinforced plastic (FRP) with signal trim summing board
- 3-Years on weighbridge steel structure,  
2-Years on load cells, junction box and summing board



# CLYDESDALE FLOOR SCALE

ISO 9001 REGISTERED





# CLYDESDALE

BY B-TEK SCALES LLC

The B-TEK Clydesdale floor scale can be custom built to meet unique application requirements.

- Specific platform dimensions
- Higher / lower capacity build
- Scale height
- Access covers
- Brackets or guides
- Equipment mounting hardware
- Custom color paint
- Special logo or lettering

### Options:

- Scale indicators
- Printers
- Ramps
- Pit frames
- Bump guards
- Remote junction box
- Floor mount indicator stand
- Integral indicator stand
- FM approved load cells
- Stainless steel load cells
- Hermetically sealed load cells
- Floor anchor plates

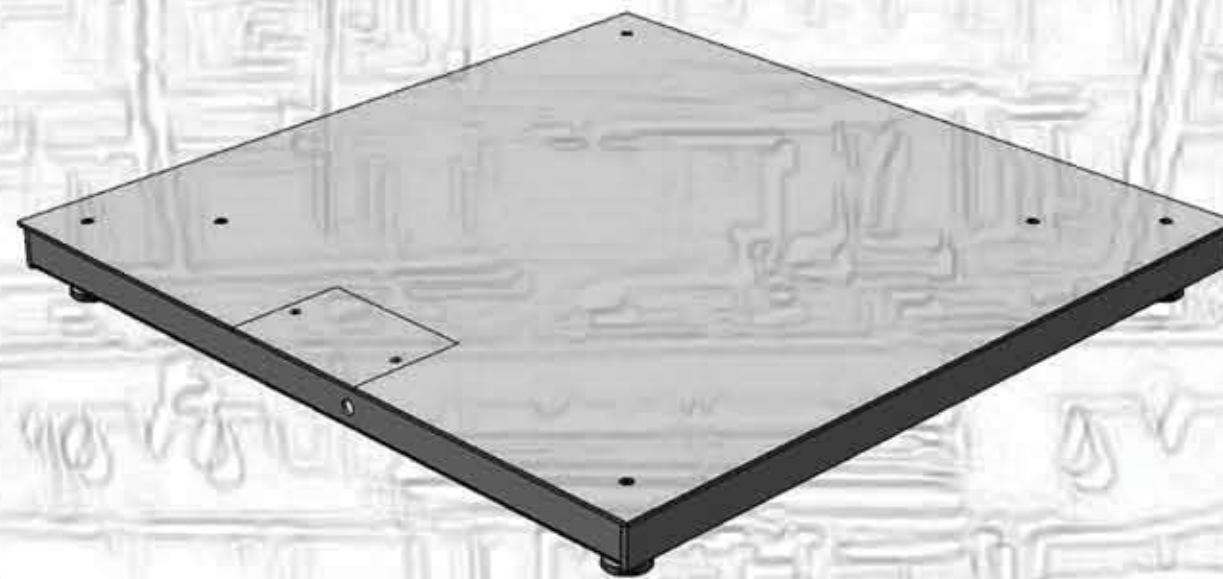

**EXPERIENCE.** B-TEK Scales has a proud history that reaches back further than its 1994 inception. With multi-generational trade experience, the B-TEK team brings over 75 years of industry know-how to the table. That long-term knowledge of the weighing industry enables B-TEK Scales to focus on bringing new and innovative solutions to our truck scale customers.

**TECHNOLOGY.** In 2003, to continually improve the technology B-TEK Scales offers its customers, B-TEK announce a joint venture with the Bilanciai Group of Modena, Italy. Bilanciai Group manufactures more than 2,200 motor truck scales per year, worldwide. Bilanciai Group's advanced manufacturing techniques and scale technologies, in conjunction with B-TEK Scales' outstanding truck scale product lines, yields many advantages that B-TEK's competitors can't offer. The B-TEK and Bilanciai Group joint venture is headquartered in Canton, Ohio USA.

**EXTENSIVE PRODUCT LINE.** B-TEK Scales offers an extensive line of eight styles of motor truck scales spanning across all industry applications. From agricultural to industrial steel, coal and aggregate applications, B-TEK Scales offers a variety of scale solutions for a wide range of budgets and requirements. B-TEK Scales has the ability to manufacture full electronic digital, analog and electro-mechanical motor truck scales.

**CUSTOMIZATION.** B-TEK is proud to be known for its ability to manufacture custom scale platforms. From non-standard sizes to retrofitted components, B-TEK's commitment to quality and service will deliver a product that fits seamlessly within our customers' current configurations.

Your B-TEK distributor is:

AC WILLIAMS SCALE CO., LLC  
ACWSALE.COM

34 Pequet Parkway  
Tonawanda, New York 14150  
1-716-694-6975  
sales@acwscale.com  
www.acwscale.com

NTEP APPROVED  
CERTIFICATE OF  
CONFORMANCE  
#94-092



1510 Metric Ave SW Canton, OH 44706  
Phone: 330.471.8900 Toll Free: 800.266.8900  
Fax: 330.471.8909 WWW.B-TEK.COM