



The B-TEK T103S indicator is ideal for general weighing and simple counting applications. Ready for use in production, packaging, warehouse, inventory and shipping / receiving areas. It's perfect for bench and floor scale applications. The ruggedly built T103S features a NEMA 4X / IP66 water resistant stainless steel housing along with a large backlit LCD display, raised tactile buttons and simple operation. The T103S is the right solution for your weighing applications that require a dependable indicator with an affordable price point.

Specifications:

- NTEP Certificate of Conformance: 08-084
- NEMA 4X / IP66 water resistant stainless steel housing
- Swivel bracket for desk or wall mounting
- Large, high-visibility backlit LCD display
- Power to drive up to four 350 Ω load cells
- Parts counting function
- Bidirectional RS-232C serial data port for printer or PC connection
- Simple parameter setup and intuitive menu structure
- High-reliability internal universal switching power supply
- Screw terminal wiring - no special connectors to solder



T103S INDICATOR

ISO 9001 REGISTERED



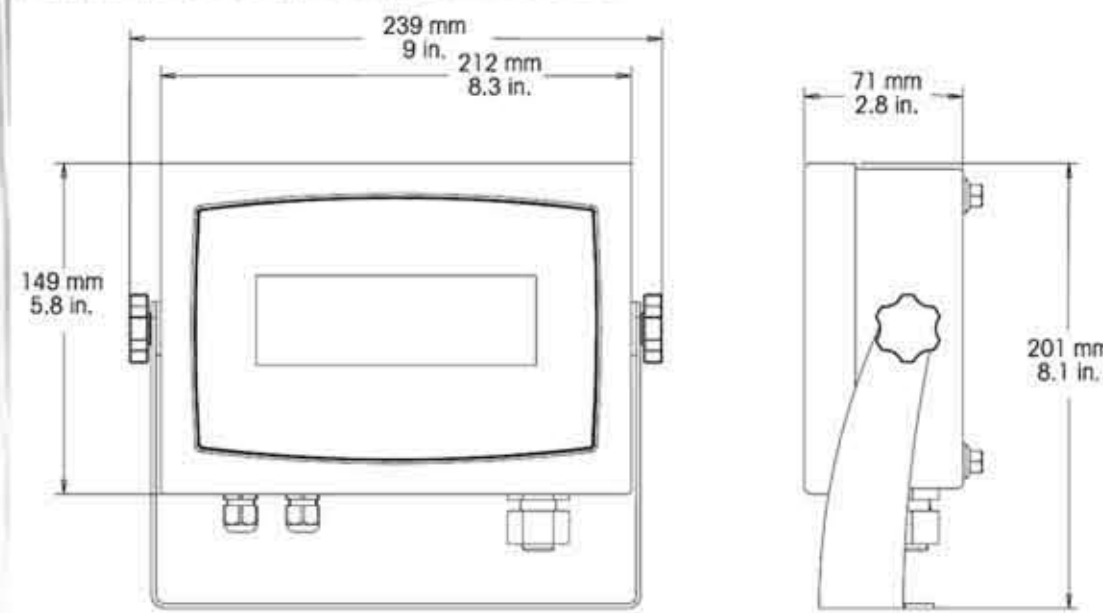

T103S INDICATOR SPECIFICATIONS

Capacity Range	5 to 20,000 lb or Kg
Maximum Displayed Resolution	1:10,000
Minimum APW	1d
Weighing Units	lb, Kg, g, oz,
Functions	Weighing, Parts Counting
Housing	Stainless Steel, NEMA 4X, IP66
Display	1 in / 2.5 cm Digit Height, 7-Segment Backlit LCD
Backlight	White LED
Keypad	4-Button Membrane
Load Cell Excitation Voltage	5 VDC
Load Cell Drive	Up to Four 350Ω Load Cells
Load Cell Input Sensitivity	Up to 3 mV/V
Stabilization Time	Within 2 Seconds
Auto-Zero Tracking	Off, 0.5, 1 or 3d
Zeroing Range	2% or 100% of Capacity
Span Calibration	5 lb or 5 Kg to 100 % Capacity
Interface	Bidirectional RS-232C
Overall Dimensions (W x D x H)	8.3 x 2.8 x 5.8 in. / 212 x 71 x 149 mm
Net Weight (lb / kg)	6.6 lb / 2.9 kg
Shipping Dimensions	10.7 x 9.2 x 7.2 in. / 272 x 234 x 182 mm
Shipping Weight (lb / kg)	8.8 lb / 4.0 kg
Operating Temperature Range	14°F to 104°F / -10°C to 40°C
Power	100-240 VAC / 50-60 Hz, Internal Power Supply

EXPERIENCE. B-TEK Scales has a proud history that reaches back further than its 1994 inception. With multi-generational trade experience, the B-TEK team brings over 75 years of industry know-how to the table. That long-term knowledge of the weighing industry enables B-TEK Scales to focus on bringing new and innovative solutions to our truck scale customers.

TECHNOLOGY. In 2003, to continually improve the technology B-TEK Scales offers its customers, B-TEK announce a joint venture with the Bilanciai Group of Modena, Italy. Bilanciai Group manufactures more than 2,200 motor truck scales per year, worldwide. Bilanciai Group's advanced manufacturing techniques and scale technologies, in conjunction with B-TEK Scales' outstanding truck scale product lines, yields many advantages that B-TEK's competitors can't offer. The B-TEK and Bilanciai Group joint venture is headquartered in Canton, Ohio USA.

EXTENSIVE PRODUCT LINE. B-TEK Scales offers an extensive line of eight styles of motor truck scales spanning across all industry applications. From agricultural to industrial steel, coal and aggregate applications, B-TEK Scales offers a variety of scale solutions for a wide range of budgets and requirements. B-TEK Scales has the ability to manufacture full electronic digital, analog and electro-mechanical motor truck scales.

CUSTOMIZATION. B-TEK is proud to be known for its ability to manufacture custom scale platforms. From non-standard sizes to retrofitted components, B-TEK's commitment to quality and service will deliver a product that fits seamlessly within our customers' current configurations.

Your B-TEK distributor is:

AC WILLIAMS SCALE CO., LLC
ACWSCALE.COM

34 Pequet Parkway
Tonawanda, New York 14150
1-716-694-6975
sales@acwscale.com
www.acwscale.com



NTEP APPROVED
CERTIFICATE OF
CONFORMANCE
#08-084



1510 Metric Ave SW Canton, OH 44706
Phone: 330.471.8900 Toll Free: 800.266.8900
Fax: 330.471.8909 WWW.B-TEK.COM